

REVISIONS				
ZONE	REV.	DESCRIPTION	DATE	APPROVED

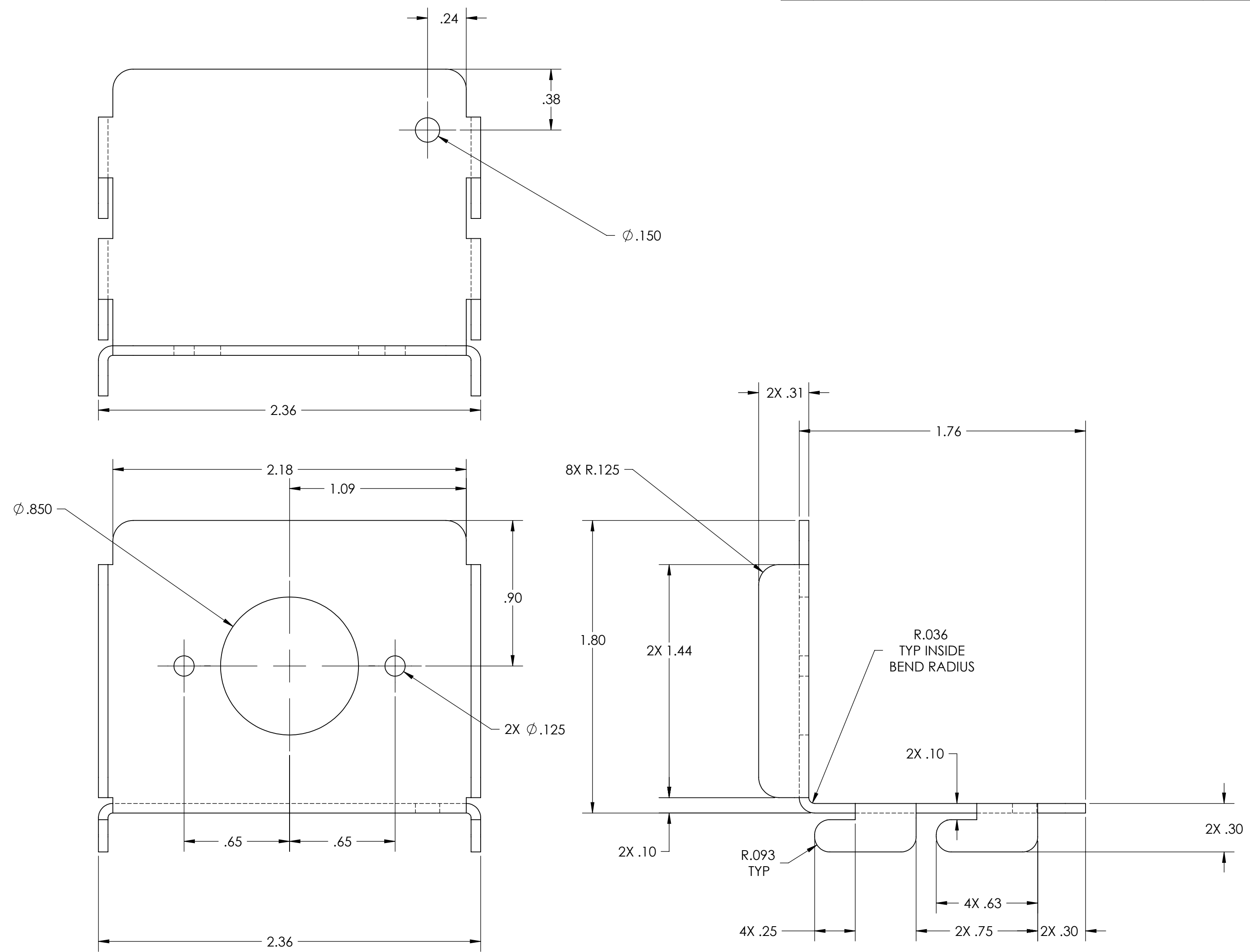

- NOTES:**
- NO USED MATERIALS ACCEPTED.
  - FINISH: PART TO BE DEGREASED AND PREPARED PER TIGER DRYLAC SPECIFICATIONS. COLOR TO BE, WHITE GLOSSY, HIGH REFLECTIVE TIGER DRYLAC **49/10410**.
  - BREAK ALL SHARP EDGES .010" MIN.
  - ALL CORNERS MUST BE FABRICATED TO MATE, NO GAPS ALLOWED.

UNLESS OTHERWISE SPECIFIED:		NAME	DATE
DIMENSIONS ARE IN INCHES		DRAWN	D.PARROTT 12/3/2011
TOLERANCES:		CHECKED	D.BELLEROSE 12/3/2011
FRACTIONAL ±1/32"		ENG APPR.	M.WELKER 12/3/2011
ANGULAR: MACH ± 1/2°		MFG APPR.	
BEND ± 1/2°		Q.A.	
TWO PLACE DECIMAL ±0.01		COMMENTS:	
THREE PLACE DECIMAL ±0.005			
FOUR PLACE DECIMAL ±0.0025			
INTERPRET GEOMETRIC TOLERANCING PER:		TITLE: <b>ENTER TITLE NAME</b>	
MATERIAL:		SIZE	DWG. NO.
16 GA (.059) CRS		<b>C</b>	P-H-033-NEW-2
FINISH:		REV	A01
SEE NOTE #2		SCALE: NTS	
NEXT ASSY	USED ON	SHEET 1 OF 3	
APPLICATION	DO NOT SCALE DRAWING		

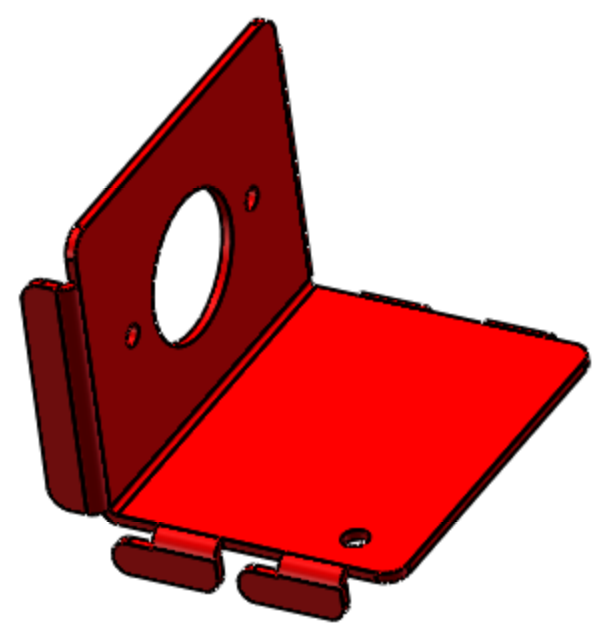
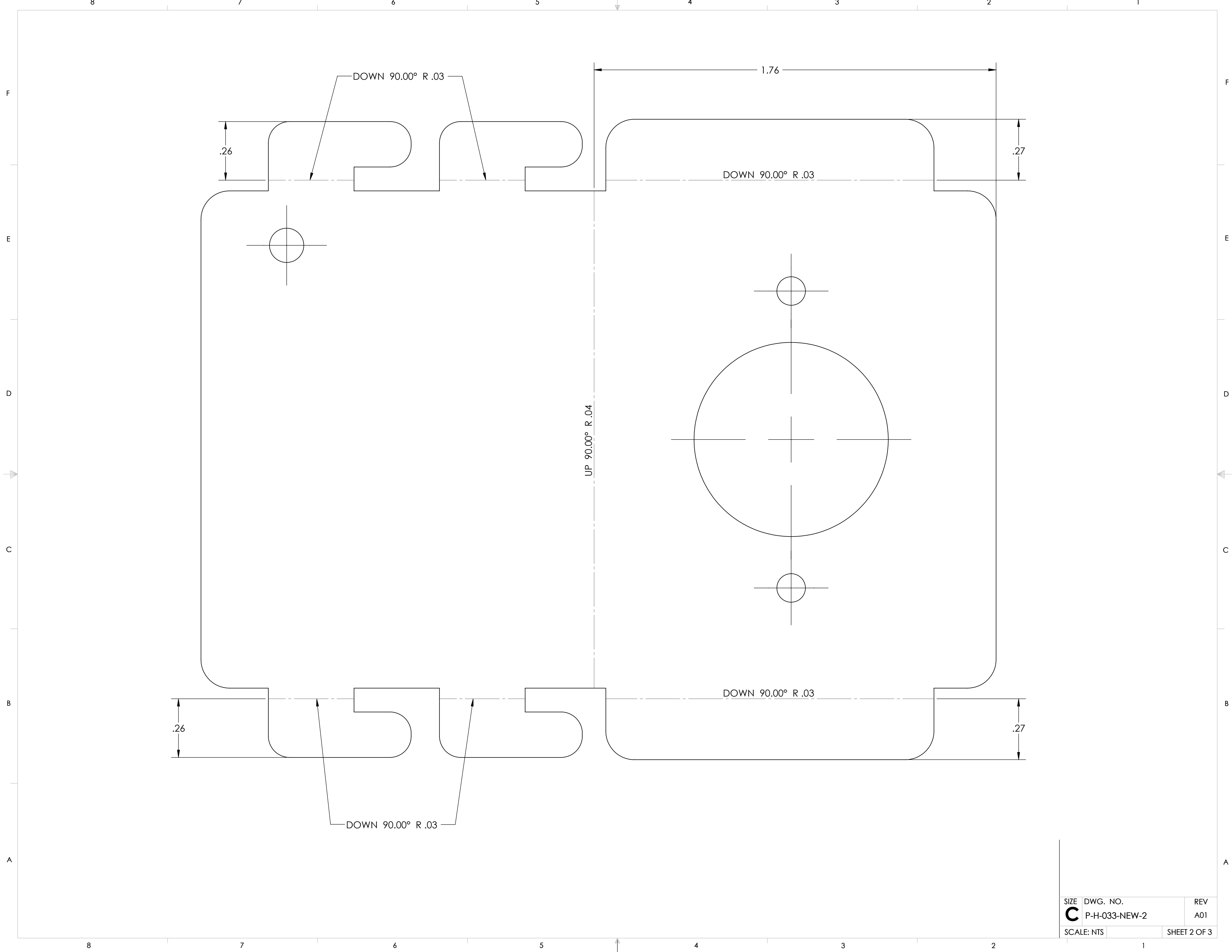

SIZE	DWG. NO.	REV
C	P-H-033-NEW-2	A01
SCALE: NTS	SHEET 2 OF 3	

